

SHELVING: UNIVERSAL

Item Numbers 8390-8397, 8410-8416

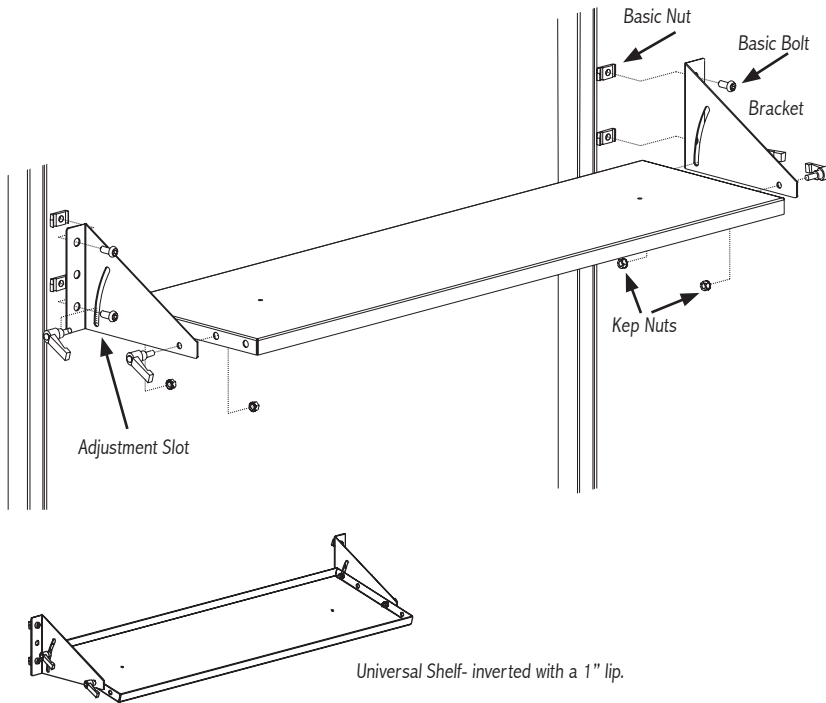

ACCESSORIES

PARTS AND HARDWARE	QUANTITY
Metal Universal Shelf	1
Brackets	2
Basic Bolts	4
Basic Nuts	4
Handles	4
Kep Nuts	4
7/32 Allen Wrench	1
Other Items Needed (not included)	
Phillips head screwdriver or drill	
Tape Measure	
Level	

• **Note: Universal Shelf can be installed as flat surface or sloped with a 1-inch lip.**

1. Insert Basic Bolt into holes on shelf bracket. Secure with Basic Nut and turn only one revolution. Repeat for other side of bracket.
2. Position brackets as shown. Insert Basic Nuts attached to shelf bracket tabs into frame channel. Turn Basic Bolt 90 degrees clockwise to grip.
3. Slide brackets to desired height. Measure or use a level to ensure brackets are at the same height. Tighten brackets on frame or uprights.
4. Position shelf to line up with adjustment slots on bracket. Insert handle from outside into adjustment slots and secure with kep nut. Repeat for all four handles.

SHELVING: WIRE

Item Numbers 8400, 8401, 8403, 8406

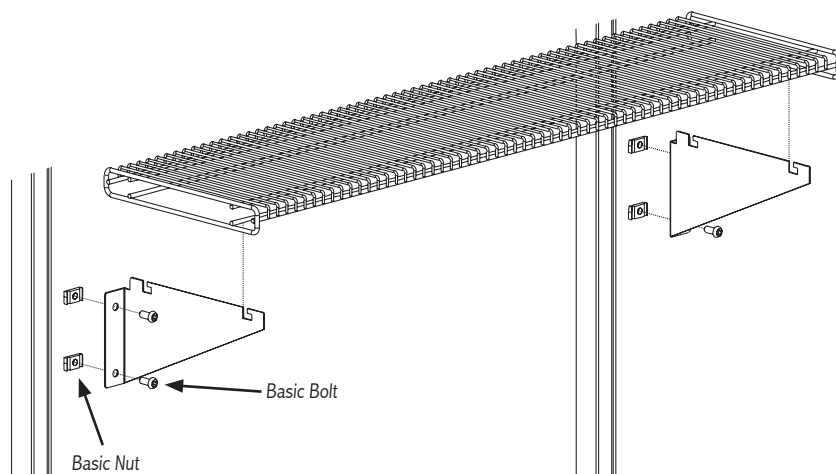

PARTS AND HARDWARE	QUANTITY
Wire Shelf	1
Brackets	2
Basic Bolts	4
Basic Nuts	4
7/32 Allen Wrench	1
Other Items Needed (not included)	
Tape Measure	
Level	

1. Insert Basic Bolt into holes on shelf bracket. Secure with Basic Nut and turn only one revolution. Repeat for other bracket.
2. Position brackets as shown. Insert Basic Nuts attached to shelf bracket tabs into frame channel. Notches indicate top of bracket. Turn Basic Bolt 90 degrees clockwise to grip. Measure or use a level to ensure brackets are at the same height.
3. Attach the shelf to the bracket. Nest shelf in notches and pull forward to lock in place. Tighten brackets on frame or uprights.